

# ENGLISH

1	GENERAL SAFETY REGULATIONS .....	19
1.1	LIST OF RESIDUAL RISKS.....	19
1.2	SAFETY REGULATIONS APPLYING TO INSTALLATION AND MAINTENANCE OPERATIONS .....	19
1.3	INDIVIDUAL PROTECTIVE DEVICES (IPD) TO BE USED .....	20
2	DEVICE IDENTIFICATION .....	20
2.1	ATEX MARKING (potentially explosive environment).....	20
2.2	PLATE .....	20
3	TECHNICAL CHARACTERISTICS.....	20
3.1	OPERATING CONDITIONS .....	21
3.2	LIQUIDS TREATED.....	21
3.3	NOISE LEVEL.....	21
4	INSTALLATION .....	21
4.1	SHIPPING.....	21
4.2	PLACEMENT .....	21
4.2.1	INSTALLATION WITH COUPLING FOOT.....	22
4.2.2	DRY INSTALLATION WITH COOLING JACKET.....	22
4.2.3	PUMP INLET .....	22
4.3	CONNECTION TO THE POWER MAINS AND DETERMINATION OF THE ROTATION DIRECTION.....	22
4.4	INSTALLATION OF FLOATING SWITCHES.....	22
5	MAINTENANCE.....	23
5.1	OIL CHECK AND CHANGE IN THE MECHANICAL SEAL CHAMBER.....	24
5.2	CHECKING PARTS SUBJECT TO WEAR .....	24
5.3	CHECKING THE BEARINGS .....	24
5.4	COUPLING PARTS .....	24
5.5	MAIN PARTS.....	24
5.5.1	COOLING JACKET.....	24
5.5.2	MECHANICAL SEALS.....	24
5.5.3	TIGHTENING THE ROTOR (2 poles).....	24
5.5.4	PUMP BODY (2/poles) .....	24
6	MINOR PROBLEMS: CAUSES AND SOLUTIONS .....	25
7	DISPOSING OF ELECTRIC PUMPS.....	25
8	ELECTRICAL CONNECTIONS .....	25
8.1	SINGLE-PHASE ELECTRICAL CONNECTION .....	25
8.2	THREE-PHASE ELECTRICAL CONNECTION .....	25
8.3	THERMAL PROBES.....	25
8.4	CONDUCTIVITY PROBES .....	25



This symbol indicates instructions concerning the safety of operators and of the electric pump



This symbol indicates instructions concerning risks of electric shocks



This symbol indicates instructions applicable to explosion-proof models (-EX)

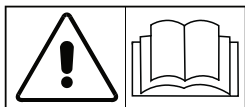

Please keep this manual safely for future reference.  
Read this manual carefully



## 1 GENERAL SAFETY REGULATIONS

To install the product correctly and use it safely, read this manual carefully before undertaking any operation.

Keep this manual in an easily accessible and clean place.

The pump installation operations and electrical connections must be carried out by qualified technical personnel skilled in electrical and mechanical fields and trained to deal with the hazards connected to places subject to risks of explosion, following the instructions given in paragraph "4 INSTALLATION" carefully.

Do not use the electric pump for any operation not expressly indicated in paragraph "3.1. OPERATING CONDITIONS" of this manual.

Do not tamper with the product in any way to change its performance or operating conditions; any operation of this type will not only immediately invalidate the guarantee, but will also place full responsibility on the user for any damaging event which may occur during operations.

Do not operate the electric pump in the air apart from the time necessary to check the rotation direction (max. for a few seconds).

Follow the instructions given in paragraph 4.3.

Do not swallow the product, or any part thereof.

Do not allow the product to come into direct contact with the body, or any part thereof, especially after its use.

Warning! The electric pump can not be powered, and therefore cannot operate, in tanks where people or animals come into direct contact with the water.

If breakages occur in any of the product's electrical parts, this can cause leakage of the electrical current into the surrounding liquid, therefore the intrinsic safety of the product must be guaranteed via the power supply network, which must have a correctly scaled differential overload switch.

These electric pumps are not suitable for manipulating liquids for nutritional use.



### 1.1 LIST OF RESIDUAL RISKS

Even when used correctly the product presents the residual risks typical of all equipment connected to the mains electricity supply:

- **RISK OF ELECTRIC SHOCK.**

- **RISK OF BURNS.** When carrying out maintenance operations immediately after the unit has been disconnected from the power supply.



### 1.2 SAFETY REGULATIONS APPLYING TO INSTALLATION AND MAINTENANCE OPERATIONS

To safely perform maintenance operations, always follow the procedure below:

- Operations involving the replacement or repair of mechanical parts and/or electrical components must be carried out by skilled personnel;

- Stop the electric pump and close the inlet and outlet shutters, if fitted;

- Check that the electric pump is disconnected from the mains. To disconnect the electric pump from the mains, disconnect the phase leads first, then the yellow-green earth lead (noting down their colours first);

- If the electric pump is submerged, remove it from the tank;

- If the electric pump has been in use, wait until the external temperature falls below 50°C

- Replace broken or worn parts with original spares only.

If in doubt, consult the manufacturer before performing any repair or replacement operations.

Since the electric pumps may be used in wells and septic tanks which may contain poisonous GASES, comply with the following precautions:

- NEVER work alone when carrying out maintenance;

- VENTILATE the well before beginning work;

- safety ropes must be attached to anyone lowered down into a well, and suitable means must be provided to allow a swift return to the surface if necessary.

Keep out of reach of children. The product is not suitable for incompetent or inexperienced people.

Do NOT put hands or objects near or into the inlet port or grating or into the outlet port on the side.



Do NOT install the pumps in WELLS, TANKS or OTHER ENVIRONMENTS where GAS may be present: RISK OF EXPLOSION (except -EX versions).

Do not move the pump by means of the cable, see relative plate on cable.

The unit's installation and maintenance must be carried out by trained personnel.

To guarantee the pump's correct operation and mechanical resistance, the following requirements must be met:

There must be a float fitted which cuts off the power supply when the level of the liquid drops below a given danger level, to ensure the hydraulic parts are always covered to guarantee the priming.

In general the field of application for cast iron is with fluids with pH levels 6 and 14. It also offers good resistance to corrosion, with concentrations of chlorides in liquids ranging from pH11 to pH 14.

Do not allow the ends of power cables to come into contact with any liquid, including the liquid being motor-driven pumped.

Power supply cable:

The cable fastening must prevent the cable being subject to bending, tearing and compression;

The cable can also be fitted in a pipe to ensure it never comes into contact with the inflammable gases and/or liquids;

simply remove the plastic union on the cable inlet and screw on the cable holder pipe, the assembly will be hermetically sealed.

Do not pull the power supply cable to move the pump.



### 1.3 INDIVIDUAL PROTECTIVE DEVICES (IPD) TO BE USED

When handling the product, especially if already installed, always wear the following items of protective clothing: Accident-prevention shoes, safety goggles, accident-prevention gloves and a leather apron or similar form of protection. Every time maintenance or repair operations are performed on installed electric pumps, particularly those which are immersed in dangerous liquids or septic tanks, all parts must be thoroughly cleaned and washed with water or specific products.

## 2. DEVICE IDENTIFICATION

A metal identification plate stating all the product specifications is applied to the electric pump. Refer to the data on this plate when seeking information or clarifications.

### 2.1 ATEX MARKING (potentially explosive environment)



According to EN 60079-0 the plate coding summarises the following:



: product in conformity with the regulations with CE mark suitable for the product

**0496**

: identification number of the body that does the production check



: explosion-proof apparatus intended for use in potentially explosive environments;

**II** : (group) high-level protection system in potentially explosive environments;

**2** : (category) electric pump intended for use in areas where explosive environments may originate from air and gas mixtures, vapours, mists or air/dust mixtures

**G** : (gas) the electric pump is protected in areas where flammable gases, vapours or mists are present;

**D** : (dusts) the electric pump is protected in areas where flammable dusts are present;

**Ex** : European Ex;

**d** : electrical equipment for potentially explosive environments – explosion-proof casings "d";

**k** : non-electrical equipment for potentially explosive environments – protection by immersion in fluid "k";

**c** : non-electrical equipment for potentially explosive environments – protection by manufacturing safety standard "c";

**IIB** : (explosion group) type of potentially explosive environment in which the electric pump will be used;

**T5** : corresponds to 100°C and is the maximum surface temperature that the electric pump can safely reach;

**tD A21** : protection through holder; method A for constructions in area 21

**IP68** : maximum degree of protection against the penetration of both solid bodies and fluids (30 m depth);

**X** : The pump installation must be carried out by qualified technical staff skilled in electrical and mechanical fields and trained to deal with the hazards connected to places subject to risks of explosion. The wired box must also be suitable for the place of installation

### 2.2 PLATE

The electric pump is fitted with a plate bearing the following information:

- Homologation EX (II 2GD Ex dkc IIB T5 tD A21 T100°C IP68 X);
  - certificate number: DNV-MUNO.0496.ATEX.07/3450 X;
  - Pump type (NAME);
  - Version (accessories installed and mechanical sealing materials);
  - Voltage rating;
  - Current absorbed from the mains;
  - Power absorbed by the pump;
  - Frequency;
  - Power factor;
  - Rotation speed;
  - Degree of protection of the casing: IP68 (declared by the manufacturer);
  - Rated capacity;
  - Rated head;
  - Number of strokes;
  - Insulation class;
  - Max. immersion depth;
  - Year of construction and serial number;
  - Service factor S1 with casing covered, S3 (25%) with motor floating;
- S1 = only with motor fully submerged or using the cooling jacket  
S3 = with the hydraulic part submerged and the motor floating

## 3 TECHNICAL CHARACTERISTICS

The electric pump specifications are stated on the metal plate and on the packaging.

Pump body and rotor in EN-GJL-250 cast iron, remaining parts in EN-GJL-250 cast iron (UNI EN 1561 - 1563).



### 3.1 OPERATING CONDITIONS

- Power supply voltage: SINGLE-PHASE and THREE-PHASE as indicated on the plate. Max permissible variation: ± 10% of ratings stated on the data plate.
- Pump immersion depth: Max. depth 30 metres below liquid level.
- Liquid temperature: Maximum temperature of motor-driven pumped liquid: 40 °C.
- Maximum permissible number of starts per hour: 20 for up to 4 kW power 15 for 4 to 7.4 kW; 10 for 7.5 to 45 kW; 5 for over 45 kW; at regular intervals in all cases.

To prevent the entrainment of air caused by turbulence of the flow, and consequent malfunctioning of the electric pump, ENSURE that the liquid does not fall directly onto the inlet, and that the inlet is sufficiently submerged to prevent the formation of vortices.

Wells and collection tanks: The dimensions of wells and tanks should be sufficient to avoid an excessive number of start-ups per hour.

For submersible electric pumps not equipped with cooling jackets the level of the liquid must never fall below the cover of the electric pump's motor.

- Protection rating: IP 68
- Field of application: drainage and/or transfer of sewage.
- Field of application: sewage from cesspools and drainage in areas where EXPLOSIVE GASES AND DUSTS are present (-EX)
- Service factor: S1 for fully submerged electric pumps, S3 with the percentage indicated on the adhesive metal plate, for partially submerged electric pumps.

The explosion-proof versions, indicated by the initials -EX, are APPROVED in compliance with the explosion-proof protection requirements stated in point 2.1 (standards EN 60079-0, EN 60079-1, EN 1127-1, EN 13463-1, EN 13463-5, EN 13463-8, EN 61241-0) for operation in wells and tanks where EXPLOSIVE GASES AND DUSTS are present and, in any case, in areas classified as zones 1 or 21. WARNING: any maintenance operation that modifies the components of the electric pump can result in a serious RISK of EXPLOSION. These pumps MUST be used ONLY in environments mentioned in the above explosion-proof protection category.



Make sure that the electric pump is not operated outside its characteristic curve.

These electric pumps are not suitable for manipulating liquids for nutritional use.

These electric pumps may not be used in tanks or other locations in which the machine may come into contact with parts of the body.

The pumps can operate in a continuous cycle S1 below the liquid level, or in a discontinuous cycle S3 (25%) with only the hydraulic part immersed in the liquid.

### 3.2 LIQUIDS TREATED

These are liquids containing small and medium/sized solid particles, filamentary particles etc and generally drainage liquids, sewage, purification waters, and those resulting from by civil and industrial processes.

Suitable for environments containing group II A and/or II B gases (regular hydrocarbon gases).

Also suitable for environments containing fuel/dust mixtures with ignition temperatures above 100°C

### 3.3 NOISE LEVEL

Submersible electric pumps present acoustic pressure levels of less than 70 dB (A) when immersed and in any case less than 80 dB if installed dry.

## 4 INSTALLATION

### 4.1 SHIPPING

Before installation, read and apply the safety procedures in paragraphs 1.2 and 1.3 carefully

Mass according to table 1 - 1/a - 1/b.

For electric pumps weighing 30 kg or less moving and lifting may be performed manually using the handle fitted on the upper part of the electric pump. Electric pumps weighing 30 kg or more must be moved or lifted using a suitable mechanical device according to the weight of the electric pump.



NEVER use the power cable or float cable to lift and move the unit. Use the appropriate handle or lifting eyelet.

Carry out a visual inspection of the packing and its contents to ensure that no damage has occurred. If there is any sign of significant damage, contact ZENIT without delay.

Check that the specifications indicated on the data plate are as required.

Before making any power connections or installing the electric pump, turn the shaft with the relative wrench to ensure that it rotates freely.

### 4.2 PLACEMENT

Before installation, read and apply the safety procedures in paragraphs 1.2 and 1.3 carefully.

The electric pump installation and wiring-up operations must be carried out by a skilled technician as outlined in chapter 1.



Always check that the electric pump is not connected to the electricity supply before performing any operations on it.

Before placing three-phase electric pumps, check the rotation direction, following the instructions in paragraph 4.3. The pumps can be set up either for mobile use, fitted to a base plate accessory, or in fixed posts. If free-standing, the electric pump outlet must be connected by an elbow and union to a flexible hose whose diameter must not be smaller than the electric pump outlet diameter. The hose should preferably be of the type with a spiral reinforcement in order to ensure a smooth flow of the liquid around bends or changes in direction. If fixed, the electric pump should be connected to a metal pipe, incorporating a check valve with free return flow and a gate shutoff valve. In this instance the stability of the electric pump is assured by the rigid pipe.

#### 4.2.1 INSTALLATION WITH COUPLING FOOT

This type of installation is envisaged for all types of submersible electric pumps with a horizontal inlet.

Electric pumps with an automatic coupling foot are the most suitable for fixed installations as they allow easy maintenance and cleaning without draining the liquid collection tank or undoing any bolts. For electric pumps where this option is provided (contact ZENIT for information), proceed as follows:

1. First fasten the coupling foot with coupling base at the bottom of the tank using expansion bolts, making sure the guide pipes (to be fitted later on, as outlined in point 3) are resting on the free edge of the cover, where the pump will be lowered.
2. install the delivery pipe with the check valve and gate shutoff valve;
3. screw/slot two guide pipes on the coupling foot, fixing them in the upper part using the spacer bracket provided by the manufacturer; this will ensure they are kept parallel;

The electric pump can now be lowered into place using a galvanised chain or rope hooked around the eyelet or handle on the top of the motor cover and, thanks to the two guide pipes, it will fit perfectly in place on the foot.

Fig. 1 on page 76 shows the installation diagram for use with the coupling foot.

#### 4.2.2 DRY INSTALLATION WITH COOLING JACKET

If the electric pump is supplied with a cooling jacket, read the booklet enclosed with this manual and follow the instructions.

#### 4.2.3 PUMP INLET

The pump inlet may have a suitably-sized grating fitted on it to ensure no foreign matter larger than the pump's passageway can enter the unit. Do not remove the grating and make sure it is always kept clear, to prevent damage and reduced pump performance.



#### 4.3 CONNECTION TO THE POWER MAINS AND DETERMINATION OF THE ROTATION DIRECTION

All the operations involved in the connection to the power mains must be carried out by qualified technical staff, as stated in chapter 1. The loose ends of the cable must be connected with a suitable junction box when the connections made in a potentially explosive area or with a normal casing if the connection is in a safe area. Whatever the case, all connections must comply with the installation regulations in force.

**WARNING:** when wiring up the unit, connect the yellow-green earth lead first, then the other leads, as indicated in chapter 8 "ELECTRICAL CONNECTIONS".

Check that the power supply voltage and frequency match the ratings indicated on the electric pump data plate and that the power absorbed by the electric pump is less than the maximum current available.

When wiring up single-phase pumps, the condenser and the circuit breaker condenser, if fitted, must be connected by the user in an area where there is no risk of it being triggered.

Before installation, check that the power line is earthed and complies with current regulations and that the electric pump cables are undamaged.

To protect the electric pump motor, use a suitable overload cut-out for the electrical specifications stated on the data plate.

A diagram illustrating the correct power supply for the electric pump can be found in chapter 8 "ELECTRICAL CONNECTIONS".

Before making the definitive three-phase connection, the electric pump rotation direction must be determined.

To determine the rotation direction, proceed as follows:

- apply the procedures of paragraphs 1.2 and 1.3;
- lay the electric pump on one side in a horizontal position and leave it unrestrained;
- temporarily connect the yellow-green lead to earth and then the live wires to the remote control switch;
- make certain there are no persons or objects within one metre of the electric pump;
- press the run button for a few seconds;
- look through the inlet to check that the rotor is rotating anticlockwise. We recommend you switch off the pump to check the rotation direction, so that you can observe the rotor when it is coming to a stop.

If the rotation direction is not correct, invert the connection of two of the three leads at the remote control switch and try again. Once the rotation is correct, MARK the connection sequence of the leads. DISCONNECT the temporary power supply and install the electric pump in its permanent position.

#### 4.4 INSTALLATION OF FLOATING SWITCHES

If the electric pump is fitted with a float, it operates completely automatically. Check that there are no objects which could impede its movement. It is very important to fix floating switches, so that their cables cannot interfere with one another, become twisted or catch on any protrusions inside the well. Floating switches should be installed in such a way that the minimum level is NEVER lower than:

- the top cover of the electric pump, in case of continuous working (S1)
- the pump body top, in case of discontinuous working (S3); in this case the pump MUST be timed (see percentage S3).

Floating switches are best secured to a rigid rod mounted inside the well. Once the installation of the electric pumps, electric panels and floating switches is complete, carry out a final inspection to check operation. Check with an ammeter that the power absorbed by the pumps is within the limits indicated on the data plate and that the floating switches are triggered at the required level.



In case of installations of EXPLOSION-PROOF pumps, you must install at least 2 float switches with certification ATEX (start and stop) and suitable for the room where they have to work.

The electric pumps are suitable for the installation in ATEX room and have this mark:



0496



II 2 GD Ex d kc IIB T5 tD A21 T100°C IP68 X

Make sure the switching from stop to start happens only and exclusively if both float switches are in the position indicated in Fig. 1.

Make sure the switching from start to stop happens only and exclusively if both float switches are in the position indicated in Fig. 2. Make sure the switching here above happens when the electric pump is totally submerged (Fig. 2).

The electric connections of the float switches must be able to guarantee the stop of the electric pump, in case of bad working of the float switch.

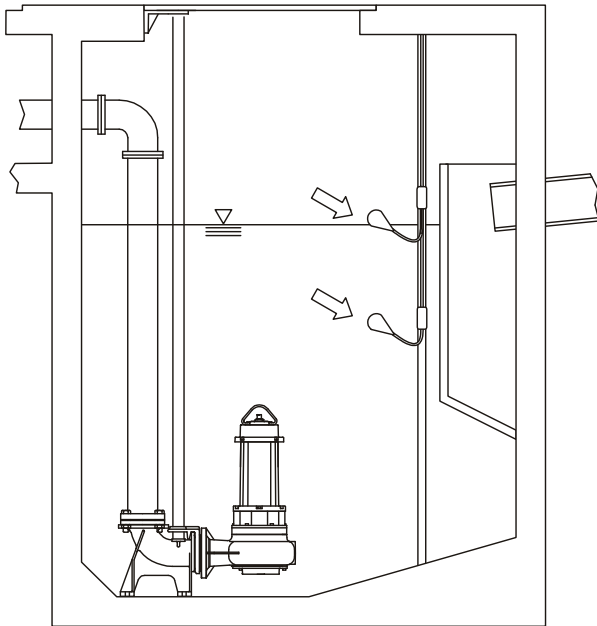

Fig. 1

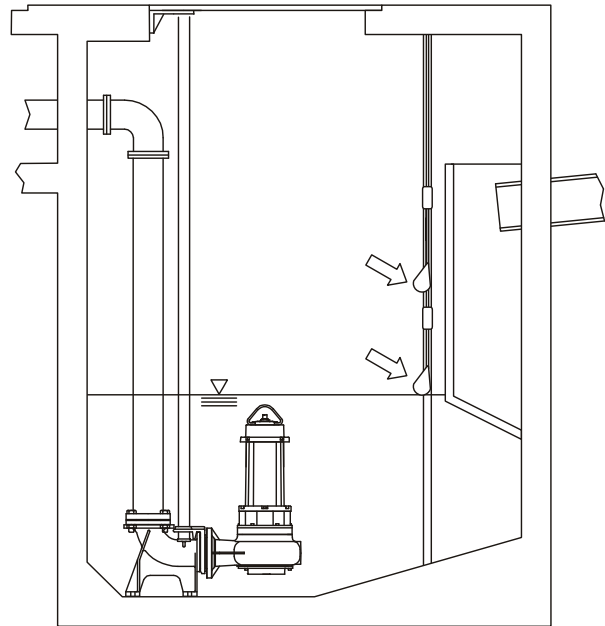

Fig. 2

## 5. MAINTENANCE

Before inspection and maintenance operations, carefully read and apply the safety procedures indicated in paragraphs 1.2 and 1.3.

**WARNING:** do not tamper the explosion-proof casing and cable clamps of any explosion-proof electric pump.

Furthermore, you are reminded that all maintenance, cleaning, installation or routine checks requiring work to be carried out on the device, must be performed safely and in compliance with the safe set-up procedure.

The safe set-up procedure provides for the following:

- All the operations must be carried out in a safe place, away from any potentially explosive environments.
- All primary sources of electricity must be removed.
- Wait until all the parts of the equipment have cooled to an acceptable temperature.



To ensure the electric pump a long, constant working life, the user is required to carry out regular checks, cleaning (to prevent the build up of dust, as prescribed in norm) maintenance and the replacement of any worn parts.

It is advisable to perform inspections on a monthly basis, or every 500-600 working hours.

- check that the power supply voltage corresponds to the values indicated on the data plate;
- check that noise and vibrations are at their original levels;
- for three-phase motors, use amperometric pincers to check the absorbance rates of the three phases are balanced and do not exceed the specifications stated on the plate.

Fig. 2 - 2/a show the blow-up of the electric pump.



## 5.1 OIL CHECK AND CHANGE IN THE MECHANICAL SEAL CHAMBER

Before inspection and maintenance operations, carefully read and apply the safety procedures indicated in paragraphs 1.2 and 1.3

The oil should be changed every 5000-7000 working hours, or at least once a year.

Proceed as follows:

- Position the electric pump horizontally;
- Unscrew the plug and drain off the oil into a suitable container, or use an oil aspiration device.
- If there is no water in the oil, then the mechanical seal is still in good condition and the chamber can be refilled with fresh oil.
- If small amounts of water are found on the bottom of the chamber, this is due to condensation collecting there; this should be considered a normal occurrence, not the result of a faulty mechanical seal;
- If a substantial quantity of water has entered the oil chamber and contaminated the oil, this indicates that the mechanical seal needs inspecting, and perhaps replacing;
- If the seal should require replacing, this must be carried out by a specialised centre;
- Refill the chamber completely with biodegradable oil such as CASTROL PRODUCT L 320 or similar; when full, extract 8% of the total oil so that there is a suitable air cushion in the chamber, making sure however that the minimum level is not below 80%.
- Once the operations outlined are complete, tighten the plug and refit the electric pump.

If none of the above is available, common Vaseline oil can be used as an exception. For any maintenance/repairs required, contact our nearest service centre.

Any repairs to the electric pump must be carried out by the manufacturer or by specialist personnel. If this is not respected, the guarantee will be invalidated and the machine may become unsafe.

Safe operation of the mechanical seals: the device's working life is estimated at 7000 hours in non-standard operating conditions (dry or by liquids with a high waste content) or 20,000 hours of use in normal operation conditions, after which it must be replaced.

During maintenance operations, replace the seals and o-rings if worn or not in perfect working condition.



## 5.2 CHECKING PARTS SUBJECT TO WEAR

Before inspection and maintenance operations carefully read and apply the safety procedures indicated in paragraphs 1.2 and 1.3

During programmed maintenance operations, or any time pump performance is reduced, or vibrations and noise increase, the hydraulic parts subject to wear must be checked and, if necessary, replaced. We recommend that any parts replaced must be replaced with official ZENIT spare parts. All special maintenance operations must be performed by the manufacturer, using official parts, particularly where the EX versions are concerned. In the event that the hydraulics become partially or totally blocked, they should be cleaned thoroughly with a jet of high pressure water. If the hydraulic part needs to be removed and refitted, refer to the blow/up in fig. 2 - 2/a.



## 5.3 CHECKING THE BEARINGS

The bearings will operate safely for an estimated 20,000 working hours, after which they must be replaced

Check the condition of the bearings every 7000 hours or every working year. If signs of wear or increased noise levels are detected, proceed with their replacement.

### 5.4 COUPLING PARTS

- ISO 4014 hexagonal-head screws
- ISO 4032 nuts
- ISO 4759/ 1 hollow cylindrical screws
- ISO 4753 dowels

The tools required for maintenance are supplied with the device (wrenches for cylinder or round-head socket screws).

When replacing screws, nuts or dowels, use A2-70 screws and bolts.

### 5.5 MAIN PARTS

#### 5.5.1 COOLING JACKET

To assemble the cooling jacket, first fit it in the frame until it reaches the intermediary support. Then fit the housing support on the top and fasten it with screws. Removal of the upper ring is facilitated by the two spot-faced, threaded holes into which the two screws are fitted.

#### 5.5.2 MECHANICAL SEALS

a pin wrench is required for fitting and removing the fastening ring nuts on the seals.

#### 5.5.3 TIGHTENING THE ROTOR (2 poles)

The rotor is keyed onto the shaft by means of a tapered coupling. When fitting the rotor, no axial adjustments are required, but the top screws, which can be M8/M10, must be tightened; a tightening torque of 20 Nm is required for M8 screws and 40 Nm for M10 screws. The rotor is disassembled by removing the top screw, then extracting the rotor by screwing an M12 screw into the (extractor) hole. To prevent damaging the thread on the top of the shaft, insert a spacer into the threaded hole.

##### 5.5.3.1 PUMP BODY (2/poles)

To guarantee the axial shim between the rotor and the pump body, use shimming seals between the pump body and intermediate support.

## 6. MINOR PROBLEMS: CAUSES AND SOLUTIONS

FAULTS	POSSIBLE CAUSE	SOLUTION
motor does not run	no voltage	check the power supply line
	automatic switch tripped	reset the switch and establish the cause
	rotor jammed	identify the cause of the trouble and remove it
	thermal protection triggered	resets automatically (not on -EX versions)
motor functions normally but no water is pumped	check valve jammed	clean the valve and check its operation
	blocked pipe	identify the obstruction and remove it
pump has reduced flow rate	rotor, valve or pipes obstructed	identify the obstruction and remove it
	liquid level too low	turn the pump off immediately
	incorrect supply voltage	match the voltage to the values indicated on the data plate
	wrong rotation direction (three-phase motor)	invert phases
thermal protector has been triggered	rotor jammed	identify the cause of the trouble and remove it
	liquid temperature too high	contact your nearest ZENIT dealer

## 7. DISPOSING OF ELECTRIC PUMPS

In the event that is not considered economically viable to repair a worn or damaged electric pump, this must be disposed of in full compliance with local regulations. To dispose of an electric pump, proceed as follows:

- remove any oil in the chamber and dispose of at a specialised collection centre;
- separate the plastic and rubber parts and dispose of at a specialised collection centre;
- arrange for the metal parts to be scrapped.

Do not dispose of any motor pump component in the environment.



## 8 ELECTRICAL CONNECTIONS

The device must be wired up in compliance with the plant engineering regulations in force in the area in which the operation is carried out.

In case of direct connection of the pump to the feeding line it is necessary to install upstream of this a magnetothermal – differential switch. The functionality and the electric security of Zenit pumps are guaranteed for the configuration provided by the factory, so any modification (i.e. addition of a piece of cable to that provided by Zenit) can cause the loss of the characteristics of the pump.

### 8.1 SINGLE-PHASE ELECTRICAL CONNECTION

Connect the yellow-green lead to earth and supply the leads on the electric pump as follows: BLACK lead to a line end; BLUE lead to the other line end and to condenser/circuit breaker; BROWN lead to the other end of the condenser/circuit breaker. SINGLE-PHASE electrical connection fig.3.

### 8.2 THREE-PHASE ELECTRICAL CONNECTION

Connect the yellow-green lead to earth and supply the electric pump output leads. If the electric pump has 3 leads, they must be connected to a three-phase line with voltage and frequency equal to that indicated on the data plate, or to a control panel with devices to reduce the initial current. If the electric pump has 6 leads, they must be connected to a control panel with a Y/delta switching device. If the connection is made directly to the delta, the supply voltage is the lower of those indicated on the data plate; if the connection is made to the Y, the voltage is the higher of those indicated on the data plate. The supply leads are marked as follows:

- 3 leads U – V – W;
- 6 leads U1 – U2 – V1 – V2 – W1 – W2;

THREE-PHASE electrical connection fig. 3/a.

### 8.3 THERMAL PROBES

Thermal protection is incorporated in the motors and resets automatically in the single-phase and in the three-phase versions equipped with thermistors or remote control switches. In the three-phase versions without remote control switches the thermal protection, where present, is connected to the electric pump outlet leads labelled T. The thermal protection must be connected to the corresponding terminal on the electric panel.

### 8.4 CONDUCTIVITY PROBES

Where present, the conductivity probe is inserted in the oil chamber and connected to the electric pump output lead labelled S. The probe must be connected to the corresponding terminal on the electric panel.

Tab 1/b

APN - GRN

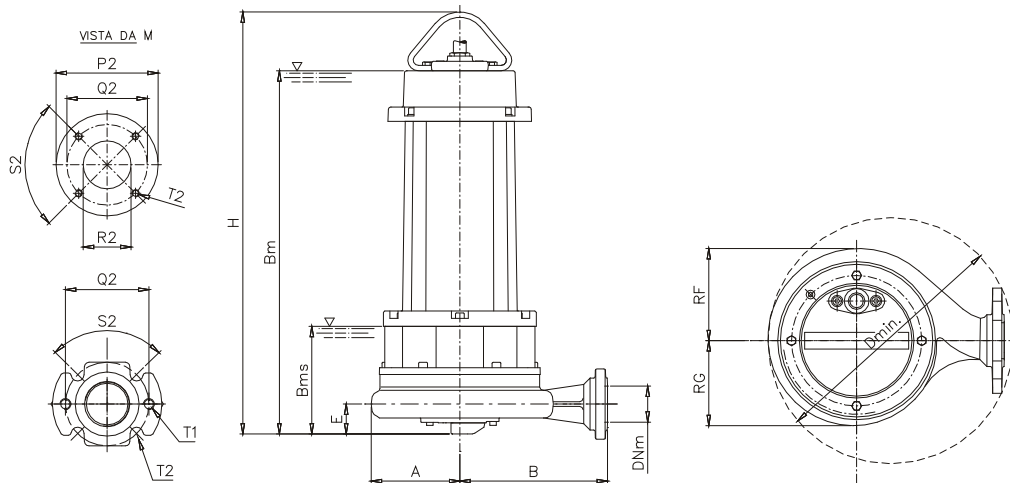

N0005FA	A (mm)	B (mm)	Bm (mm)	Bms (mm)	Dmin (mm)	DNm (mm)	E (mm)	H (mm)	RF (mm)	RG (mm)	KG
APN 250/2/G40H A1DT/50	107	160	480	164	546	1½	78	534	107	107	43
APN 300/2/G50H A1DT/50	110	195	480	165	318	2	78	536	117	107	46
APN 400/2/G50H A1FT/50	132	220	572	191	360	2	77	660	138	126	68
APN 550/2/G50H A1FT/50	132	220	572	191	360	2	77	660	138	126	71
GRN 250/2/G40H A1DT/50	107	160	444	128	546	1½	43	498	107	107	44
GRN 300/2/G50H A1DT/50	110	195	445	130	318	2	42	500	117	107	47
GRN 400/2/G50H A1FT/50	132	220	540	160	360	2	46	629	138	126	69
GRN 550/2/G50H A1FT/50	132	220	540	160	360	2	46	629	138	126	72

Tab 1/c

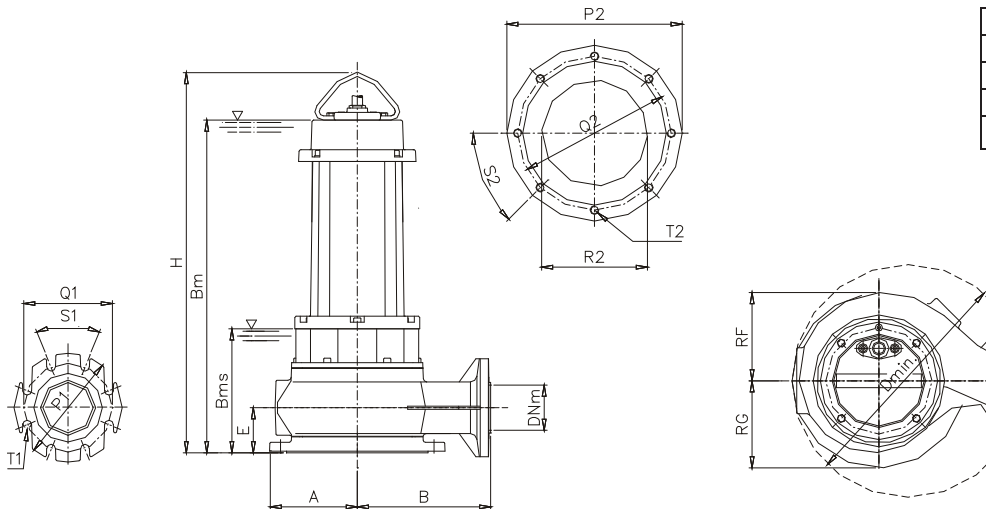

	KG
GRN 300/4/100 A1FT/50	89
GRN 300/4/80 A1FT/50	87
GRN 400/4/100 A1FT/50	92
GRN 400/4/80 A1FT/50	90

N0005OA	A (mm)	B (mm)	Bm (mm)	Bms (mm)	Dmin (mm)	DNm (mm)	E (mm)	H (mm)	P1 (mm)	P2 (mm)	Q1 (mm)	Q2 (mm)	R2 (mm)	RF (mm)	RG (mm)	S1 (°)	S2 (°)	T1 (mm)	T2 (mm)
GRN 300/4/100 A1FT/50	160	255	606	226	450	100	85	693	220	320	180	280	126	174	160	45	45	18	M16
GRN 300/4/80 A1FT/50	160	244	606	226	423	80	82	693	200	320	160	280	126	160	160	90	45	18	M16
GRN 400/4/100 A1FT/50	160	255	606	226	450	100	85	693	220	320	180	280	126	174	160	45	45	18	M16
GRN 400/4/80 A1FT/50	160	244	606	226	423	80	82	693	200	320	160	280	126	160	160	90	45	18	M16

Fig. 2/b

APN - GRN

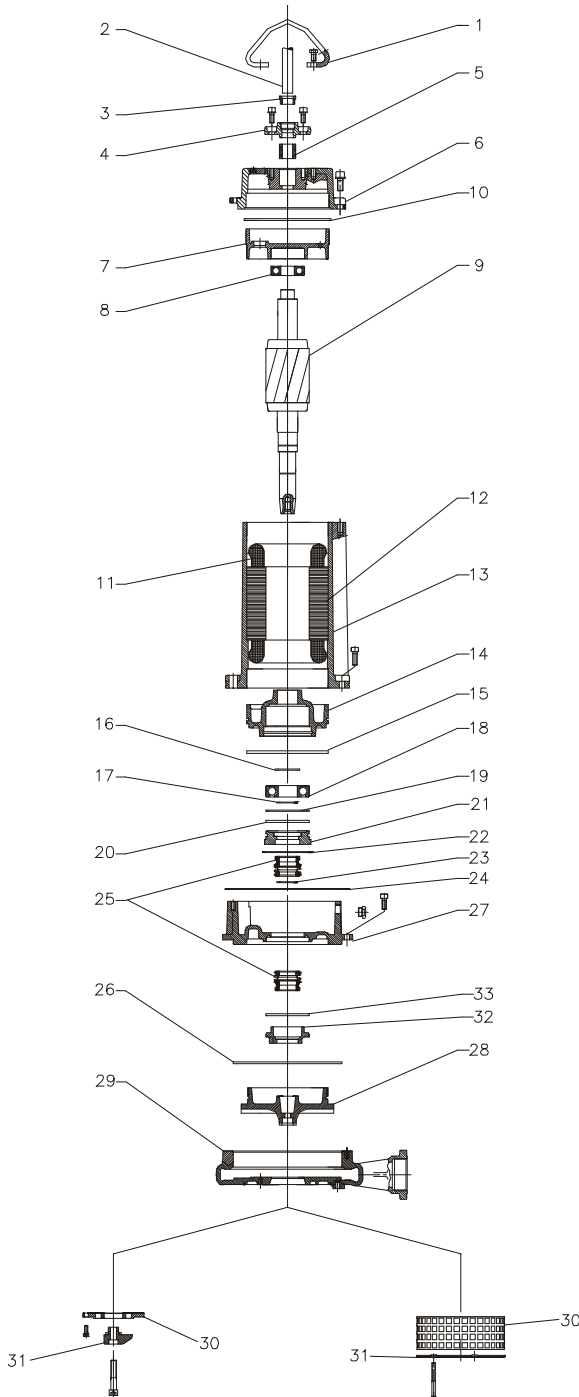

(I)

(GB)

(D)

1	MANIGLIA	HANDLE	GRIF
2	CAVO	CABLE	KABEL
3	TAPPO PRESSACAVO	NUT	SCHRAUBE
4	PRESSACAVO	CABLE GLAND	KABELLEINFUHRUNG
5	GOMMINO	CABLE GLAND	KABELLEINFUHRUNG
6	COPERCHIO MOTORE	MOTOR COVER	MOTORGEHAUSE
7	SUPP. CUSCINETTO	BEARING HOLDER	LAGER-HALTERUNG
8	CUSCINETTO	UPPER BALL BEARING	KUGELLAGER
9	ALBERO	SHAFT WITH ROTOR	PUMPENWELLE
10	O-RING	O-RING	O-RING
11	AVVOLGIMENTO	WINDING	WICKLUNG
12	STATORE	WINDING	WICKLUNG
13	CARASSA	MOTOR CASE	STATORMANTEL
14	SUPP. CUSCINETTO	BEARING HOLDER	LAGER-HALTERUNG
15	O-RING	O-RING	O-RING
16	RONDELLA	WASHER	AUFLAGESCHEIBE
17	SEEGER	SEEGER	SEEGER
18	CUSCINETTO	LOWER BALL BEARING	KUGELLAGER
19	MOLLA	SPRING	FEDER
20	O-RING	O-RING	O-RING
21	FLANGIA	SEALING FLANGE	FLANSCH
22	SEEGER	SEEGER	SEEGER
23	SEEGER	SEEGER	SEEGER
24	GUARNIZIONE	GASKET	DICHTUNGSFEDER
25	TENUTA	MECHANICAL SEAL	GLETRINGDLCH TUNG
26	GUARNIZIONE	GASKET	DICHTUNGSFEDER
27	SUPPORTO INT.	INTERM. SUPPORT	ZWISCHENHALTERUNG
28	GIRANTE	IMPELLER	LAUFRAD
29	CORPO POMPA	PUMP BODY	GITTER - PUMPENGEHAUSE
30	GRIGLIA - PIATTO TRIT	STREINER - CUTTING DISK	HAUSE - SCHNEIDEWERTZUG PLATTE
31	COPERCHIO - COLTELLO	COVER - CUTTER	GEHAUSE - SCHNEIDEWERTZUG

(F)

(E)

1	POIGNEE	PUNO
2	CABLE	CABLE
3	ECROU	EJE
4	SERRE CABLE	PRENSACABLE
5	SERRE CABLE	PRENSACABLE
6	COUVERCLE	TAPA MOTOR
7	SUP. DU ROULMENT	SOP. RODAMIENTO
8	ROULMENT	COJINETE
9	ARBRE ET ROTOR	ROTOR CON EJE
10	O-RING	O-RING
11	BOBINE	BOBINADO
12	BOBINE	BOBINADO
13	CARCASSE MOTEUR	CARCASA MOTOR
14	SUPPORT DU ROULMENT	SOPORTE RODAMIENTO
15	O-RING	O-RING
16	RONDELLE	ARANDELA
17	SEEGER	SEEGER
18	ROULMEN	COJONETE
19	RESSORT	RESORTE
20	O-RING	O-RING
21	BRIDE POUR ETANCHEITE	RETEN PARA ACEITE
22	SEEGER	SEEGER
23	SEEGER	SEEGER
24	JOINT	EMPAQUETADURA
25	TENUE MECHANIQUE	CIERRE MECANICO
26	JOINT	EMPAQUETADURA
27	SUPPORT INT.	SOPORTE INT.
28	ROUE MOBILE	TURBINA
29	CORPS DE LA POMPE	CUERPO BOMBA
30	CREPINE - DISQUE DE COURPAGE	REJA - DISCO TRITURADOR
31	COUVERCLE - HACHOIR	TAPA - CUCHILLA

(I) COLLEGAMENTI ELETTRICI  
 (GB) ELECTRICAL CONNECTION  
 (D) STROMANSCHLÜSSE

(F) CONNEXIONS ELECTRIQUES  
 (E) CONEXIONES ELÉCTRICAS

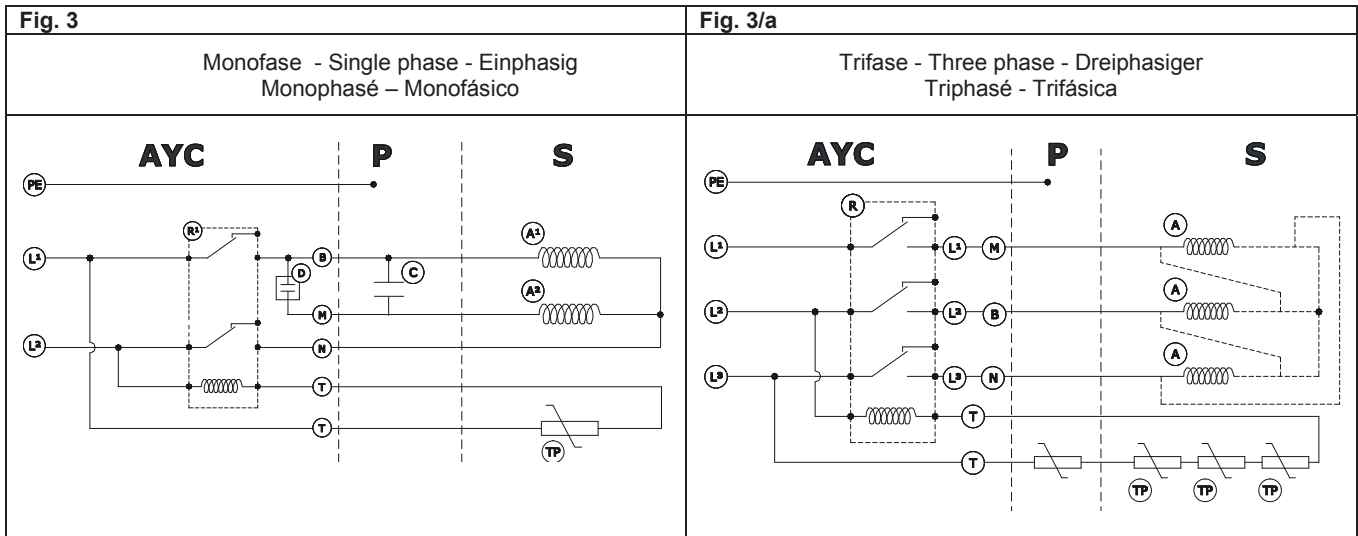

	(I)	(GB)	(D)	(F)	(E)
<b>S</b>	Statore	Stator	Ständer	Stator	Estator
<b>P</b>	Pompa	Pump	Pumpe	Pompe	Bomba
<b>AYC</b>	A vostra cura	At your cost	Dafür müssen Sie sorgen	Par vos soins	Por cuenta del usuario
<b>CST</b>	Scatola CST opzionale	Optional CST box	Gehäuse CST als Optional	Boîte CST optionnelle	Caja CST opcional
<b>A<sup>1</sup></b>	Avvolgimento di marcia	Run winding	Betriebsumwicklung	Bobinage de marche	Bobinado de marcha
<b>A<sup>2</sup></b>	Avvolgimento di avvio	Start winding	Startumwicklung	Bobinage de mise en marche	Bobinado de encendido
<b>A</b>	Avvolgimento	Winding	Umwicklung	Bobinage	Bobinado
<b>TP</b>	Protezione termica	Thermal protection	Wärmeschutz	Déclencheur thermique	Protección térmica
<b>M</b>	Marrone	Brown	Braun	marron	Marrón
<b>B</b>	Blu	Blue	Blau	bleu	Azul
<b>N</b>	Nero	Black	Schwarz	noir	Negro
<b>PE</b>	Terra (giallo-verde)	Earth (yellow-green)	Erde (gelb-grün)	terre (vert-jaune)	Tierra (amarillo-verde)
<b>OP</b>	Protezione per i sovraccarichi	Overload protection	Überlastungsschutz	Protection contre les surcharges	Protección contra sobrecargas
<b>G<sup>1</sup></b>	Galggiante opzionale	Optional float	Schwimmer als Optional	Flotteur optionnel	Flotador opcional
<b>C<sup>1</sup></b>	Condensatore necessario	Obligatory capacitor	Notwendiger Kondensator	Condensateur nécessaire	Condensador necesario